

OTOFACTS

Japan Standard Check

Report ID: PxeQgb20v7kXL297
Generated: March 10, 2026 14:24:10
Purchased: March 9, 2026 12:04:04

Vehicle Details



Image for illustration purposes only

VIN ¹

WP0ZZZ98ZCS751062

Year Manufactured

2012

Make & Model

PORSCHE CAYMAN

Basic Information

Year Registered	2012
Body Type	ABA-987MA120
Grade/Trim	CAYMAN

Technical Specifications

Engine	MA120
Drive Type	MIDSHIP
Transmission	Automatic Transmission

Quick Summary

Title Information ³	✓ Deregistered for Export
Accident / Repair	✓ No Problems Found
Odometer Rollback	✓ No Problems Found
Manufacturer Recall	✓ No Problems Found
Contamination Risk	✓ No Problems Found
Safety Grade ⁴	Unknown

Accident / Repair History

Problem Type	Reported	Date	Source	Details	Airbag
Collision	✓ No Problems				
Malfunction	✓ No Problems				
Theft	✓ No Problems				
Fire Damage	✓ No Problems				
Water Damage	✓ No Problems				
Hail Damage	✓ No Problems				

Odometer & Mileage Analysis

Last Recorded Mileage	43,634 km
Vehicle Age	0 years

Normal (Under 20k km/year)

Average yearly usage: 43,634 km/year

Odometer History

Date	Source	Mileage	Change	Daily Average
Nov 24, 2021	MLIT	34,600 km	—	—
Oct 1, 2024	MLIT	40,600 km	+6,000 km	5.8 km/day
Aug 28, 2025	USS Tokyo	43,634 km	+3,034 km	9.2 km/day

Data sourced from official registries and auction houses; availability varies by vehicle.

Calculated metrics are system-generated estimates based on historical records and provided for reference only.

Use History

Use In The Contaminated Regions ⁵	Radioactive Contamination Test Fail ⁶	Commercial Use ⁷
✓ No Records Found	✓ No Records Found	✓ No Commercial Use Record Found

Detailed History

Event Date	Location	Odometer Reading ²	Data Source	Details
2012	-	-	PORSCHE	Manufactured
2012-09	-	-	MLIT	First registration
2021-11-24	-	34,600 km	MLIT	Inspection
2024-10-01	Nagoya	40,600 km	MLIT	Inspection
2025-08-28	Chiba	43,634 km	USS Tokyo	Auctioned
2025-09-24	Nagoya	-	MLIT	Last registration

Manufacturer Recall History

Date Reported	Data Source	Affected Part	Details
✓ No Recall Records Found			

Vehicle Assessment ⁸

Driver's Seat

Points	Evaluation	Goal Average
unknown	unknown	unknown

Front Passenger Seat

Points	Evaluation	Goal Average
unknown	unknown	unknown

Breaking Performance Tests ⁹

Dry Road	Wet Road
unknown	unknown

Based on Japan New Car Assessment Program (JNCAP) standards established in FY2009.

Vehicle Specification

Basic Information

Make	PORSCHE	Model	CAYMAN
------	---------	-------	--------

Grade	CAYMAN	Model Code	ABA-987MA120
Classification Code	0019,0020	Body Type	COUPE
Frame Type	?	Specification Code	16260

Dimensions & Weight

Length	4.345	Width	1.800
Height	1.305	Wheelbase	2.415
Weight (kg)	1410	Ground Clearance (cm)	?
Front Tread	1.490 [1.485]	Rear Tread	1.535 [1.530] [1.520]
Body Rear Overhang	?	Minimum Turning Radius (mm)	5200

Engine & Power

Engine Model	MA120	Displacement	2890
Engine Maximum Power	265ps(195kW)/7200rpm	Engine Maximum Torque	30.6kg?m(300N?m)/4400?6000rpm
Cylinders		Fuel Consumption	9.5
Electric Engine Type	?	Electric Engine Power	?
Electric Engine Maximum Output	?	Electric Engine Maximum Torque	?
Fuel Tank Equipment	64	Mufflers Number	?

Transmission & Gearing

Transmission Type	AT	1st Gear Ratio	3.909
2nd Gear Ratio	2.292	3rd Gear Ratio	1.654
4th Gear Ratio	1.303	5th Gear Ratio	1.081
6th Gear Ratio	0.881 7 SPEED:0.617	Reverse Ratio	3.545

Chassis

Front Shock Absorber	?	Rear Shock Absorber	?
Front Stabilizer	?	Rear Stabilizer	?
Front Tires	205/55 ZR 17	Rear Tires	235/50 ZR 17
Front Shaft Weight	630	Rear Shaft Weight	780
Wheel Alignment	MIDSHIP	Chassis Number Position	

Safety

Main Brakes Type	HYDRAULIC TYPE DISK	Side Brakes Type	?
Airbag Position	?	Riding Capacity	2
Maximum Speed	?	Stopping Distance	?9.40(100)
Additional Notes			

This section represents the standard or base model factory specifications of the vehicle. Dealer options and customization are not reflected here.

Auction Records

1 / 1 Auction	PORSCHE CAYMAN VIN: WP0ZZZ98ZCS751062 #75651 USS Tokyo 2025-08-28
----------------------------	--

Auction Result	available Vehicle is available and open for bidding
Auction Date	2025-08-28
Auction House	USS Tokyo
Auction Lot Number	75651
Auction Grade	4 Well Maintained
Make	PORSCHE
Model	CAYMAN
Registered Year	2012
Mileage *	43,634 km
Displacement	2,900 cc
Transmission	Automatic Transmission
Color	RED
Model Code	987MA120
Region	unknown

Japan auction houses often record rounded-up or rounded-down mileages. Mileage handwritten on the auction sheet may differ from that of the database. The fluctuation is usually within 1,000km. Please refer to the mileage in the auction sheet for the exact value.

Auction #1 Images

輸入車プライムコーナー

75651	車種 (自動車以外は輸入)	排気量	型式	年式 4
	初年度登録年月 H24/9月	車名 ボルシェ ケイマン	グレード ベースグレード	
	2900	ABA-987MA120		

車検	R 8年 9月 30日	シフト	FAT	標準 SR 風	純正 TV	PS ナビ	PC エアロ
走行	43,634 km	冷房	AC	セールスポイント スポーツクロノパッケージ ディーラー車 左ハンドル PDKスポーツプラス パドルシフト ナビゲーション&地デジTV&bカメラ			
外色	色種 レッド	カラー		※色紙と一緒に送付下さい			
燃料	ガソリン	内装色	ブラック系	※色紙と一緒に送付下さい			
輸入区分	ディーラー	ハンドル	左	※色紙と一緒に送付下さい			

リサイクル 料	21,010円	乗車定員	2人	登録地	横浜	306	ち	8608
○注意事項 (※※:不具合箇所および状況等)				車台No	WPD7798ZCS751062			
ユーザー買取車				シリアルNo				

ディーラー車 左ハンドル
ハーフレザーシート&ヒーター

○検査員報告

- Sハウスキズ凹
- 外品マフラー
- ルーム内スレ
- 天張タルミ
- 小キズ小凹

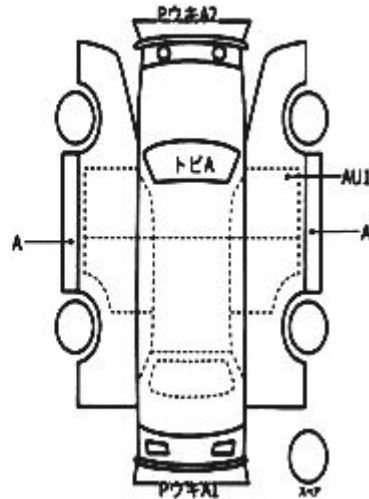

【舞台内寸】	x	x	(cm)
長さ	434 cm	幅	180 cm
		高さ	130 cm

Report Guide

This report is only based on information supplied and available to OTOFACTS as of 09 Mar 2026, 08:04 PM (Asia/Kuala Lumpur).

1 Chassis number – a unique identification number of the vehicle in Japan (same as VIN in the USA or Europe)

2 Mileage – Japan auction houses often record rounded-up or rounded-down mileages. Mileage handwritten on the auction sheet may differ from that of the database. The fluctuation is usually within 1,000km. Please refer to the mileage in the auction sheet. If there is a *, \$ or # in the mileage, it means the mileage has been tampered with.

3 Title information

- Registered – qualified for driving in Japan
- Deregistered Temporarily – not qualified for driving in Japan, usually a temporary title during the ownership change
- Deregistered Completely – not qualified for driving in Japan, the vehicle is determined to be scrapped
- Deregistered for Export – not qualified for driving in Japan, the vehicle is determined to be exported

4 Determining the overall collision safety performance evaluation – For the driver's seat, the results of the full-wrap frontal collision test, offset frontal collision test, and side collision test are added together and evaluated to 6 different levels. For the Frontal passenger's seat, the results of the full-wrap frontal collision test and the side collision test (results for the driver's or the front passenger's seat are used) are added together and evaluated to 6 different levels.

Regular vehicle inspection – All vehicles in Japan must undergo regular vehicle inspections (shaken). New cars need to be tested after three years, and then vehicles must be tested every two years thereafter. A vehicle inspection (shaken) is compulsory for all vehicles with an engine size over 250cc. It ensures that all vehicles on the road are properly maintained and safe to drive. The test also checks that vehicles have not been illegally modified; if they are found to have been modified, they are not allowed on the road.

5 Use in the contaminated regions – The Fukushima Daiichi nuclear disaster was a catastrophic failure at the Fukushima I Nuclear Power Plant on 11 March 2011, resulting in a meltdown of three of the plant's six nuclear reactors. As a result, some areas in the following prefectures were contaminated: Fukushima, Miyagi, Ibaraki, Tochigi.

6 Radioactive contamination test – radioactive contamination inspection that was started in July 2011 as a preventive measure for exporting contaminated vehicles from Japan. The inspection is being conducted since in all sea ports of Japan under the supervision of The Japan Harbor Transportation Association (JHTA).

MLIT – Ministry of Land, Infrastructure, Transport and Tourism.

7 Commercial Use - Vehicle used to transport goods or passengers for the profit of an individual or business.

8 Japan New Car Assessment Program – the Ministry of Land, Infrastructure, Transport and Tourism (MLIT) and the National Agency for Automotive Safety & Victims' Aid (NASVA) have taken measures for safety, one of which is to assess commercially available vehicles through a variety of safety performance tests and release the resulting information compiled into the "New Car Assessment Program". The objective of Japan New Car Assessment Program is to increase the use of safe automobiles by providing an environment in which users can easily select such vehicles. This also promotes the development of safer vehicles by automobile manufacturers. Neck injury protection for rear-end collision performance test, rear seat passenger's protection for frontal collision performance test, rear passenger's seat belt usability evaluation test and seat belt reminder for passengers evaluation test are started in FY2009. [Click here for more information.](#)

Understanding the Assessment Levels:

Level	Points Range	Performance Rating
Level 5	10.6 to 12.0	Excellent safety performance
Level 4	9.1 to 10.5	Very good safety performance
Level 3	7.6 to 9.0	Good safety performance
Level 2	6.1 to 7.5	Moderate safety performance
Level 1	6.0 or less	Basic safety performance

How to read Auction Grades and Inspection Reports

Auction grade is the overall assessment of a car given by the Japanese car auction house's inspectors. There are currently over 115 auction house locations that test and provide the auction grades base on the general condition of the car or vehicle. Though different houses have various methods of determining each grade; the systems are likely similar and giving the almost same result.

The grades are usually showed as numbers or letters for the overall grade based on the visible and mechanical condition. Some auctions use Letter –A, B, C, D or E to describe the exterior and/or interior condition of the car, in addition to the overall grade, where A > B > C > D > E.

Overall Grade

Grade	Description
Grade 6 or higher or "S"	Considered as brand new, less than 12 months of old, and/or with a mileage under 10,000 km.
Grade 5	As good as new, with exceptionally low mileage.
Grade 4.5	Very slightly used, mileage of up to 100,000 km.
Grade 4	Used condition, pre-loved but well looked after with very light blemishes.
Grade 3.5	You can find noticeable scratches, dents, rust or corrosion (rare). Inside the vehicle often appear tears, cigarette holes, stains.
Grade 3	Visible huge scratches, dents, paint stains, rust and corrosion. Interior full of tears, cigarette holes or food stains.
Grade 2	Poor condition, usually featuring unrepaired accident damage or corrosion, but the car is functional.
Grade 1	Modified or disaster cars like flood.
Grade R or 0	Accident history/repared. Repaired parts are mostly mentioned in auction sheet.
Grade RA	Minor accident cars that have been fully repaired.
Grade RB	Slightly more serious than RA.
Grade RC	Pillar or frame has been changed/repared.
Grade R2	Accident history and mostly rust or corrosion issue.
Grade * or *** or Blank Grade	Non running car, needed a forklift to be moved, major accident.

Interior or Exterior grade

Used car auction grade for the interior/exterior is as follows:

Interior Grading:

- A** – New vehicle's condition.
- B** – Car is in good condition, the interior looks nice and tidy.
- C** – Small food's stains or cigarette's holes could be found inside the car.
- D** – Inner vehicle consists of cigarette's mark, stains, tears or smell.
- E** – Interior of the car is in bad condition. Grade E means all mentioned above and even worse.

Exterior Grading:

- A** – A pristine exterior condition.
- B** – Some small scratches up to 15cm could be found.
- C** – Scratches up to 30 cm or dents could be seen.
- D** – Visible scratches, rust or corrosion are detected.
- E** – The car is in bad shape. Rust, corrosion and exterior breakdowns are plenty.

For advanced-level buyers

If an auction sheet is available, inspection markings (image below) indicated by the inspectors can tell you more about the vehicles condition.

OTOFACTS

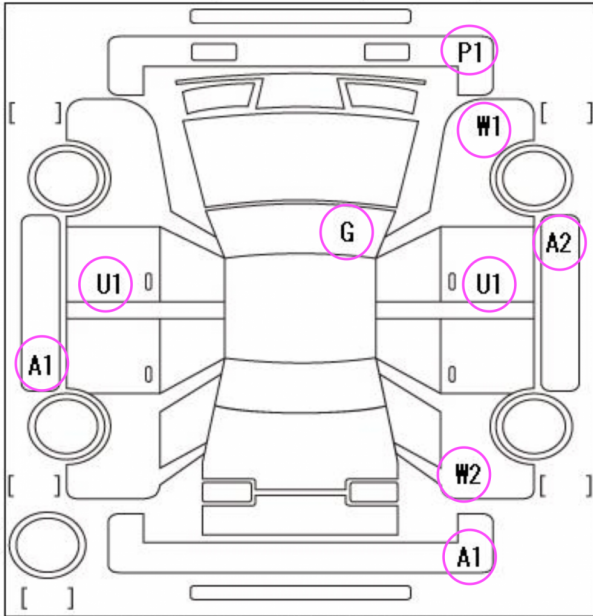

If the auction inspection sheet is available, look for these marks & understand the vehicles condition.

Inspection Markings Guide

A1 - Small scratch.

A2 - Scratch.

A3 - Big scratch.

B or (B1 to B4) - Larger dents. These are more serious than pin dents (U).

C or (C1 to C4) - Corrosion. C on the body can mean a small stone chip has some surface rust or there is a spot of rust on the edge of a sunroof which might be easily addressed. C indicated on the wheel arches is a sign there is serious corrosion.

E1 - Few dimples.

E2 - Several dimples.

E3 - Many dimples.

G - Stone chip on glass. You might see a G, X or even an A marked on the windscreen. This usually indicates a small stone chip or scratch and often these are quite small, the size of a pin head or so, and not easily visible. They are the sort of things most cars pick up through normal use and if you see them noted it doesn't mean the windscreen needs

replacing.

H - Faded paint.

P or (P1-P4) - Paint damage. Fading, scratches or discolouration from sun damage, polishing, peeling, crazing or poor paintwork.

R - Repaired windshield crack.

RX - Repaired windshield crack (must be replaced).

S1 - Rust.

S2 - Heavy rust.

U - Pin dents. Only a small dent such as you would pick up in the carpark.

U1 to U4 - Moderate dents. Used to denote the size of the dent with 1 being the smallest.

W1 - Hardly detectable repair mark/wave (hardly detectable).

W2 - Repair mark/wave.

W3 - Visible repair mark/wave (needs to be repainted).

X - Windshield crack (must be replaced).

XX - Replaced.

X1 - Small windshield crack (approximately 1cm).

Y or (Y1-Y4) - Cracks or hole. Usually in bodykits or lights and often not a major issue as repair or replacement is fairly simple.

OTOFACTS

A copy of your report can be accessed anytime via your [Profile](#).

Need Help With Reading The Report?

Visit our website for frequently asked questions and our guide to help you better understand your report.

[Frequently Asked Questions](#)

General Disclaimers

This report has been supplied on the [Terms and Conditions](#) set out on the OTOFACTS website.

The data used to compile this report has been sourced from various independent and government sources, as a result OTOFACTS can accept no responsibility for the accuracy or completeness of information.

OTOFACTS